



ATM LIGHTING PROIECTOR LED CU INSTALARE RAPIDA 30W

Proiectorul FLX 300 LED de tip teava este destinat zonelor industriale cu potential exploziv cum ar fi platformele petroliere, rafinarii, benzinarii etc. conceput pentru zonele 1,21 si 2,22. Dispozitivul este echipat cu o mufa speciala ce permite instalarea rapida. Grila de protectie si reflector disponibil ca op?iune.

Materiale folosite:

Carcas?: aluminiu turnat

Dispensor: sticla borosilicata

Caracterisitici tehnice :

Tensiune de alimentare 220-240V; 110V la cerere

Clasa de protec?ie modul: I; IK08

Grad de protec?ie: IP66, CRI: >80

Putere LED 30W

Flux luminos : 3030 lm

Factor de putere: ? 0,99

Durata de via??:> 50.000h L95B10

Temperatura de culoare: 4000K

Temperatura mediului ambiant : de la -20 ° C până la + 50 ° C

Conexiune conductor: 5x2,5 mmp

Diametru cablu: Ø mm 6-15

Sursă de alimentare: cablare transversală

Certificare: EXA 15 ATEX 0050X

Dimensiuni:

DIMENSIONS

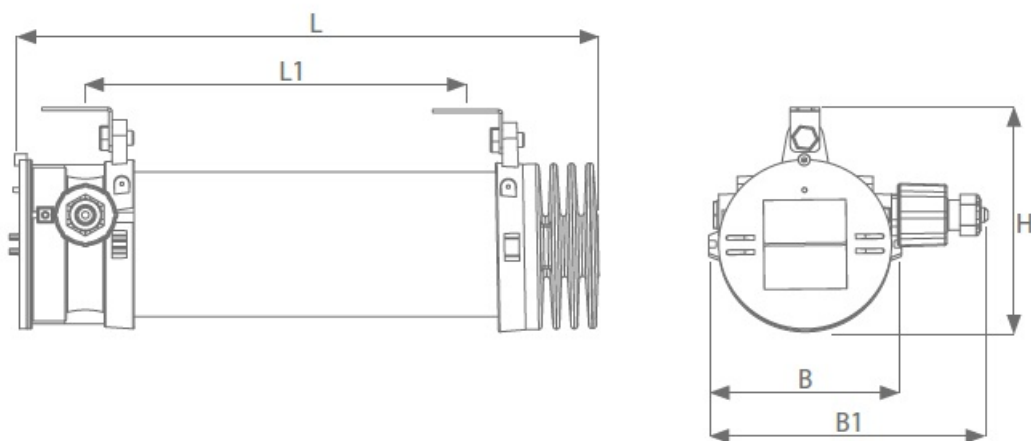

TYPE	L	L1	H	B	B1
FLX 310 LED	475	316	183	155	220

Distributie luminoasa:

PHOTOMETRY

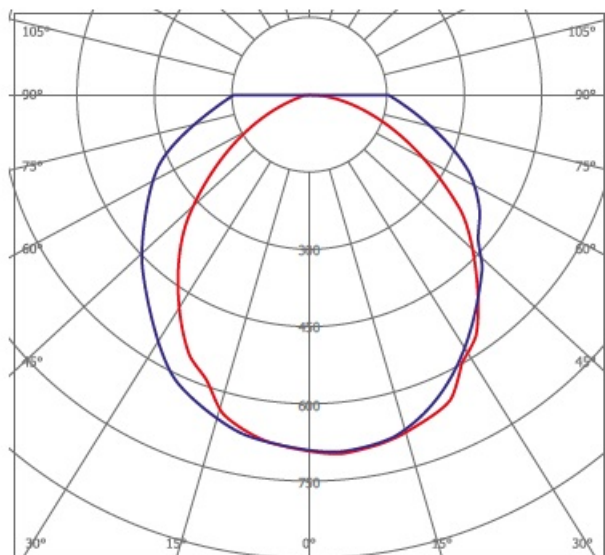

Accesorii:

Grila de protectie (FLX20-140); reflector extern (FLX20-150); set de montare pe teava (PLFS 20-120)

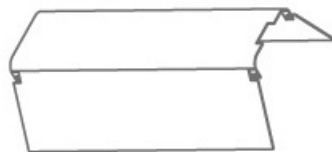
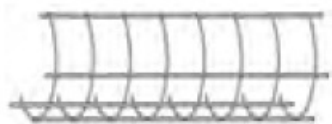

Pret: 8.048,73 LEI (TVA inclus)

Detalii online: <https://www.materialelectrice.ro/atm-lighting-flx-310-led-30w>